

### ES-1000IV ES-1000sIV

适用注塑机吨位：250~450ton  
Injection Press Range: 250~450ton



### STEC-NC2C

升级版多功能操作盒  
Upgraded multifunctional pendant

功能更多样、操作更简单便捷  
Variety function,  
Operation more convenient and easily

## 综合参数 | GENERAL SPECIFICATIONS

电源 Power Source	常用气压 Air Pressure	驱动方式 Drive System	姿势(气缸) Posture (Air Cylinder)	气动姿势部推力(气压:0.5Mpa时) Air Cylinder Driving Force (Air Pressure at 0.5Mpa)		控制箱 Control Box
				最大可搬重量 Max. Load	姿势力矩 Posture Torque	
AC200V ±10% 50/60Hz(单相) Single Phase	0.5Mpa	AC伺服马达 AC Servo Motor	90°固定 90° Fixed	标准姿势部:5kg[8kg] (含夹具重量) Incl. Chuck Weight	20.6N·m	STEC-NC2c

机种 Model	行程(移动量)(mm) Stroke				电源设备容量 (KVA) Electric Consumpton	最大消费电力 (KW) Max Power Consumpton	机器重量(kg) Net Weight		空气消耗量 (Nℓ/周期) Air Consumption (Nℓ/Cycle)
	制品上下 Ⓟ Vertical	水口上下 Ⓡ Vertical	前后 Crosswise	走行 Traverse			本体 Main Body	操作盒 Pendant	
ES-1000IV	1000	—	90~1000	1800 [1600]	1.4	1.1	248	1.1	2.31
ES-1000sIV		1050	Ⓟ245~1000 Ⓡ105~860		2.6		1.7		

Ⓟ [ ]尺寸表示选项行程。

Ⓞ 本体重量包括控制箱及电缆线的重量。

Ⓟ Ⓡ 表示制品侧手臂, Ⓡ 表示水口侧手臂。

Ⓞ 关于最大可搬重量, 详情请咨询敝司营业担当。

Ⓞ Figure in [ ] shows option stroke.

Ⓞ Net weight includes the weight of control and cable line.

Ⓞ In the column of stroke, Ⓟ stands for product side arm and Ⓡ stands for runner side arm.

Ⓞ For details of the maximum allowable weight, please confirm with our sales man.

## 标准功能 | STANDARD FUNCTIONS

取出侧 Product Extract Side	<input checked="" type="checkbox"/> 取出下降待机 Delayed arm descent	<input checked="" type="checkbox"/> 前进取出侧姿势控制 Crosswise product extract side posture control	<input checked="" type="checkbox"/> 吸着确认单元(1回路) Vacuum confirmation unit(1circuit)	<input checked="" type="checkbox"/> 自由滑移取出 Free extract for under-cut mold
	<input checked="" type="checkbox"/> 顶针联动 Ejector link	<input checked="" type="checkbox"/> 顶针后退联动 Ejector return link	<input checked="" type="checkbox"/> 水口模内开放 Runner release within mold	<input checked="" type="checkbox"/> 固定可动切换 Extraction from fixed mold
走行 Traverse	<input checked="" type="checkbox"/> 走行途中姿势 Posture control during traverse	<input checked="" type="checkbox"/> 浇口途中开放(走行/复归) Midway sprue release (Traverse·Return)	<input checked="" type="checkbox"/> 不良品排出(可计数) Defective product reject (Countable)	
	<input checked="" type="checkbox"/> 横走行待机 Delayed traverse	<input checked="" type="checkbox"/> 水口途中开放(走行/复归) Midway runner release (Traverse·Return)	<input checked="" type="checkbox"/> 初期成型品排出 Initial products release	
落下侧 Product Release Side	<input checked="" type="checkbox"/> 落下侧下降途中姿势 Posture midway descent at release side	<input checked="" type="checkbox"/> 装箱点 Point packaging	<input checked="" type="checkbox"/> 自由装箱点(8级,共512点) Point free packaging (8 stage, 512 points)	<input checked="" type="checkbox"/> 输送带启动信号 Start signal of conveyoyr
	其它 Other	<input checked="" type="checkbox"/> 3国语言切换(简体中文、日文、英文) Three language exchange (Chinese(new), Japanese, English)	<input checked="" type="checkbox"/> 插入式用户编程 Easy NC steps (User program editing)	<input checked="" type="checkbox"/> 外部存储记忆 External storage memory
<input checked="" type="checkbox"/> 设定值隐藏功能 Default blind feature		<input checked="" type="checkbox"/> 背景灯自动OFF Backlight Auto OFF	<input checked="" type="checkbox"/> USB通信端口 USB communication port	

# 选项功能 | OPTION FUNCTIONS

## 取出侧 Product Extract Side

- 吸着确认单元 (2回路)  
Vacuum confirmation unit (2circuits)
- 吸着确认单元 (4回路)  
Vacuum confirmation unit (4circuits)
- 夹具减压阀  
Chuck pressure regulator
- 旋转功能  
Rotation Unit
- 上升途中闭模  
Mold close during arm ascent
- 制品确认 (LS-4)  
Product confirmation LS-4

## 落下侧 Product Release Side

- 剪切回路(夹具内)  
Air nipper in chuck circuit
- 制品2点开放  
Release product at two different points
- 制品4点开放  
Release product at four different points
- NT剪切·可动侧(有单元)  
NT gate cutting on crossmember of moving mold side (w/unit)

## 其它 Other

- 警报灯 (红色·无蜂鸣器)  
Alarm Lamp (Red color,w/o buzzer)
- 自动快速交换用夹具 (气压式)  
Quick chuck change automatic (air sw)
- 操作盒支架  
Pendant stand
- 欧规 12 (SPI)  
EUROMAP 12 (SPI)
- 欧规 67  
EUROMAP 67

# 外观尺寸 | OUTER DIMENSIONS

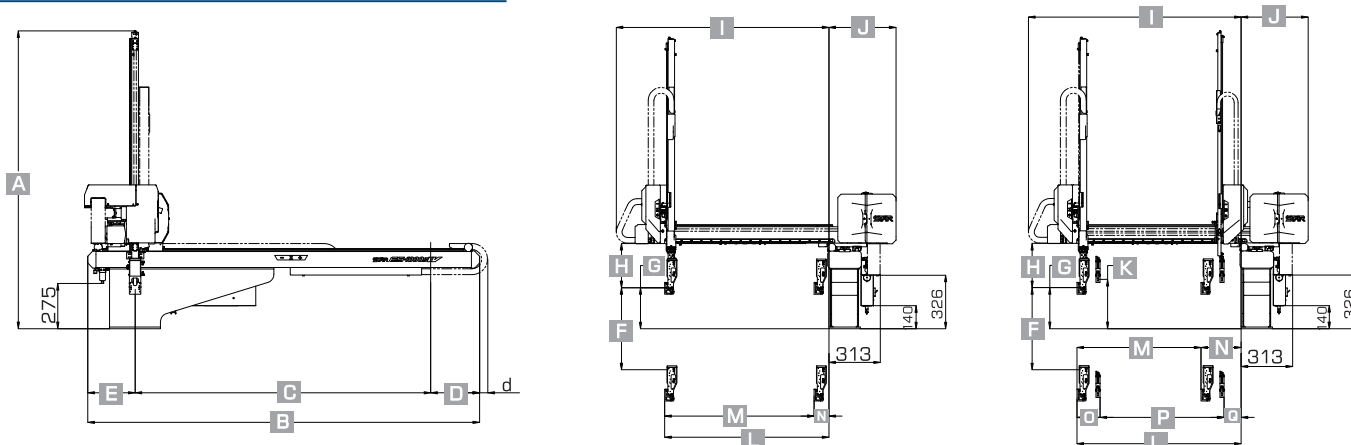

外形尺寸(mm)   OUTER DIMENSIONS		ES-1000IV	ES-1000sIV	
A	全高 / Overall height	1780	1820	
B	全幅 / Overall width	2390(2390 <sup>1</sup> )		
C	走行行程 / Traverse stroke	1800(1600 <sup>1</sup> )		
D	落下侧突出位置 / Overhang,release side	300(300 <sup>1</sup> )		
E	取出侧突出位置 / Cable guide overhang	290(490 <sup>1</sup> )		
F	Ⓟ 制品侧上下行程 / Ⓟ Vertical stroke	1000		
G	Ⓟ 制品侧上下待机位置 / Ⓟ Vertical standby	250		
H	夹具安装位置上方有效尺寸 / Bottom of crosswise to chuck mount position	265		
I	前后单元 / Crosswise arm	1295		
J	本体厚度 / Thickness	410		
K	Ⓡ 水口侧上下待机位置 Ⓡ Vertical standby	—	300	※ 反操作时E值为305、[505] <sup>1</sup> D值为285、[285] <sup>1</sup>
L	Ⓟ 制品前进MAX Ⓟ Crosswise reach max	1000		※ As anti-operator side E is 305、[505] <sup>1</sup> D is 285、[285] <sup>1</sup>
M	Ⓟ 制品前进行程MAX Ⓟ Crosswise stroke max	910	755	
N	Ⓟ 制品前后待机MIN Ⓟ Crosswise standby min	90	245	※ d值正操作时为50、[50] <sup>1</sup> 反操作时为10、[10] <sup>1</sup>
O	Ⓟ Ⓡ 接近MIN Ⓟ Ⓡ Proximity min	—	140	
P	Ⓡ 水口侧前后行程MAX Ⓡ Crosswise stroke max	—	755	※ As operator side d is 50、[50] <sup>1</sup> anti-operator side d is 10、[10] <sup>1</sup>
Q	Ⓡ 水口侧前后待机MIN Ⓡ Crosswise standby min	—	105	

Ⓟ [ ]内的尺寸表示选项行程。  
 Ⓡ 水口夹的厚度为25mm。  
 Ⓢ 姿势部厚度为74mm。但根据配管方式不同,此尺寸多少会有些不同。  
 Ⓣ 水口侧上下行程比制品侧上下行程长50mm。  
 Ⓤ \*1表示C尺寸为1600mm。  
 Ⓥ Figure in [ ] shows option stroke.  
 Ⓦ Thickness of runner chuck is basically about 25 mm.  
 Ⓧ Thickness of posture area is basically about 74 mm (depends on tubing)  
 Ⓨ Runner side vertical stroke is 50 mm longer than that of product side.  
 Ⓩ \*1 When dimension C is 1600 mm.

●因改良等原因,规格及外观有所变更时,不再另行通知,敬请包涵。All stated here is subject to change without advance notice.



## STAR中国地区销售服务网络信息

<http://www.starseiki.cn>

### 华东地区

- 大陆地区总部: 星精机械(上海)有限公司  
 地址: 上海市徐汇区桂平路555号46栋208室  
 ☎ +86-021-5423 4571
- 苏州事务所 ☎ +86-0512-6805 8385
  - 厦门事务所 ☎ +86-0592-577 9994
  - 余姚事务所 ☎ +86-0574-6253 2721
  - 青岛分公司 ☎ +86-0532-5556 5517

### 华北/东北地区

- 天津分公司 ☎ +86-022-5838 7675
- 大连分公司 ☎ +86-0411-8756 2176

### 华南/西南/华中地区

- 深圳分公司 ☎ +86-0755-2962 2620
- 广州分公司 ☎ +86-020-3708 4205
- 武汉分公司 ☎ +86-027-8425 3500
- 重庆分公司 ☎ +86-023-6036 0877
- 成都分公司 ☎ +86-028-6549 5545
- 襄阳生产工厂 ☎ +86-0710- 3311 813

### 港澳台地区

- 香港公司 ☎ +852-2687 6745
- 中日龙股份有限公司(台北市)  
☎ +886-2-2836 0039
- 台南营业所 ☎ +886-6-273 8985
- 台中营业所 ☎ +886-4-2463 1361